

Açıklamalar / Explanation

ST model S tipi loadcell alaşımli çelik malzeme nikel le kaplanmış olup zorlu çevre koşullarında dayanıklı bir şekilde dizayn edilmiştir. Hem çekme hem basma prensibi ile çalışır. ST yük hücreleri, beton santralleri, test makineleri, bunker tartımlarında, lazer kaynak göbek-vdesi ile ağır şartlarda çalışabilme özelliği vardır. Paslanmaz çelik yapıyla tam endüstriyeldir.

ST model S type loadcell alloy steel material is nickel plated and designed to be durable in harsh environmental conditions. It works with the principle of both pulling and pressing. ST load cells, concrete plants, test machines, bunker weighing, laser welding core-screw with the ability to work under heavy conditions. It is fully industrial with its stainless steel structure.

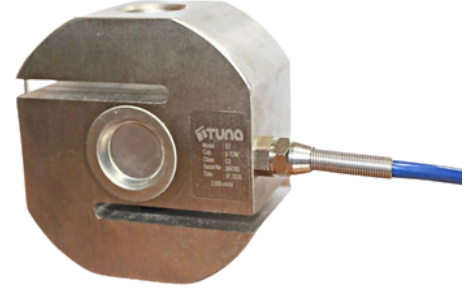

Teknik Özellikler / Technical Specifications

Hassasiyet Sınıfı / Sensitivity Class	C3	1/3000
Çıkış Duyarlılığı / Output sensitivity	mV/V	2.0 ± 0.002 (FSO)
Kapasite / Capacity	Kg	50 to 5000
Toplam Hata / Total error	%FS	± 0.020
Sıfır Balansı / Zero balance	%FS	± 0.010
Giriş Direnci / Entry resistance	Ω	385 ± 10
Çıkış Direnci / Output resistance	Ω	350 ± 3
İzolasyon Direnci / Insulation resistance	MΩ	≤ 5000
Kompanze edilmiş sıcaklık aralığı / Compensated temperature range	°C	-10 ~ +40
Çalışma Sıcaklığı / Operating temperature	°C	-35 ~ +65
Tavsiye edilen besleme voltajı / Recommended Feeding Voltage	V (DC)	5 ~ 12
Maksimum besleme voltajı / Maximum supply voltage	V (DC)	15
Minimum Yük / Minimum load	t	0
Aşırı Yükleme Kapasitesi / Overload capacity	%FS	150
Kırılma Kapasitesi / Breaking Capacity	%FS	250
Malzeme / Material	Alloy Steel/Stainless steel	
Koruma Sınıfı / Protection class	IP68	
Kablo / Cable	4x022mm ²	

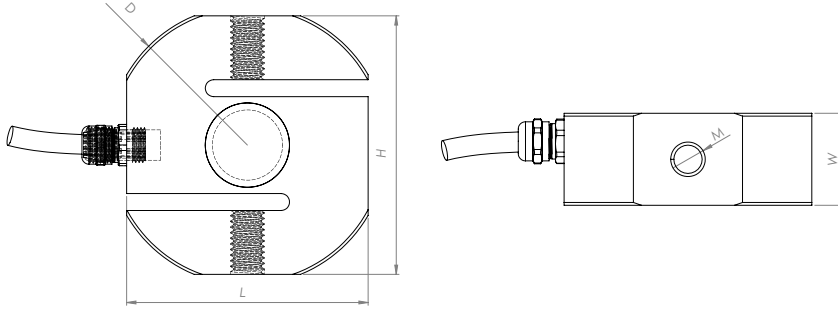
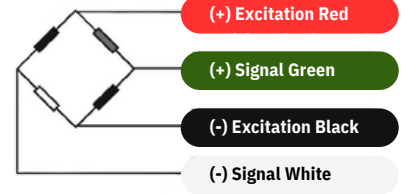

Capacity	W	H	L	D	M
50KG	19	76	66	Ø78.5	M10
100KG	19	76	66	Ø78.5	M12
200KG	19	76	66	Ø78.5	M12
500KG	25.5	76	66	Ø78.5	M12
1000 KG	32	92	86	Ø99.5	M12
2000 KG	32	92	86	Ø99.5	M16
3000 KG	32	92	86	Ø99.5	M20X1.5
5000 KG	98	95	90	Ø98	M24X2

Uygulamalar

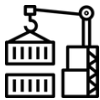

Asılı Tartım Sistemleri



Konveyör Kantarı

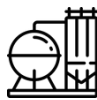

Tank & Silo Tartımı



Endüstriyel Prosesler



Test Makineleri



Palet Kantarı



Mobil Tartım Uygulamaları