

## Açıklamalar / Explanation

Tuna HC model Yük Hücreleri loadcell alaşımı çelik olarak silo tartım sistemlerinde, test makinalarında ve özel uygulamalarda kullanılmak üzere üretilmektedir. Tamamen lazer kaynakla kapatılmış ölçüm bölgesi IP68 koruma sınıfında olup zorlu endüstriyel koşullarda başarı ile çalışmaktadır.

Tuna HC model Load Cells are produced in loadcell alloy steel for use in silo weighing systems, testing machines and special applications. The measurement area, which is completely covered by laser welding, is in IP68 protection class and works successfully in harsh industrial conditions.



## Teknik Özellikler / Technical Specifications

Hassasiyet Sınıfı / Sensitivity Class	C3	1/3000
Çıkış Duyarlılığı / Output sensitivity	mV/V	2.0 ± 0.002 ( FSO )
Kapasite / Capacity	Ton	200
Toplam Hata / Total error	%FS	± 0.020
Sıfır Balansı / Zero balance	%FS	± 0.010
Giriş Direnci / Entry resistance	Ω	380 ± 20
Çıkış Direnci / Output resistance	Ω	350 ± 3
İzolasyon Direnci / Insulation resistance	MΩ	≤ 5000
Kompanze edilmiş sıcaklık aralığı / Compensated temperature range	°C	-10 ~ +40
Çalışma Sıcaklığı / Operating temperature	°C	-35 ~ +65
Tavsiye edilen besleme voltajı / Recommended Feeding Voltage	V ( DC )	5 ~ 12
Maksimum besleme voltajı / Maximum supply voltage	V ( DC )	15
Minimum Yük / Minimum load	t	0
Aşırı Yükleme Kapasitesi / Overload capacity	%FS	150
Kırılma Kapasitesi / Breaking Capacity	%FS	250
Malzeme / Material	Alloy Steel/ Stainless Steel	
Koruma Sınıfı / Protection class	IP68	
Kablo / Cable	4x022 mm <sup>2</sup>	

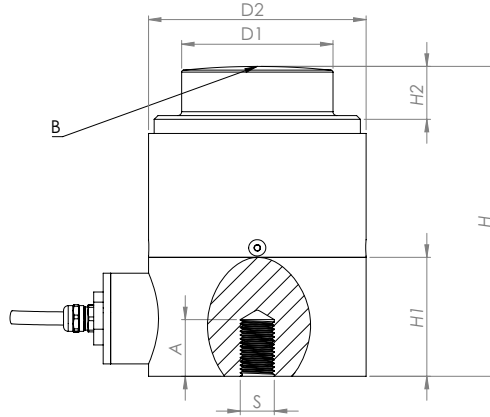
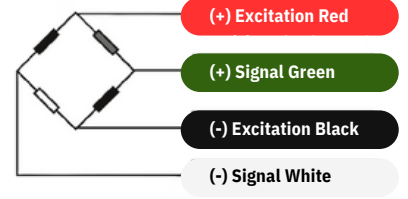

CAPACITY	H	H1	H2	D1	D2	S	A	B
200 Ton	164	63	28	Ø80	Ø114	M18	30	R400

## Uygulamalar



Taşıt Kantarları

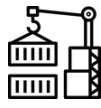

Asılı Tartım Sistemleri



Konveyör Kantarı

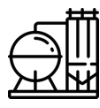

Tank & Silo Tartımı



Endüstriyel Prosesler

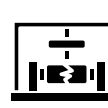

Test Makineleri



Palet Kantarı

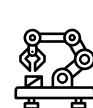

Mobil Tartım Uygulamaları